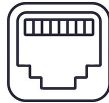
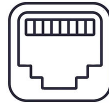
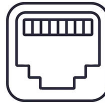

Configuration Notes (Sophos SG 115w Rev 1)

Thank you for purchasing this network appliance! To make this device useful to people who do not have a Sophos license and don't want to get one, we have installed the pfSense operating system and tested the device to ensure its working condition.

If you intend to reset pfSense to its initial settings, we still recommend that you read the remainder of this note to familiarize yourself with how pfSense interacts with this device's components.

This model has on-device labeling of physical ports. When configuring pfSense, we made interface designations consistent with this labeling to reduce confusion:

On-device markings				
	LAN	WAN	DMZ	HA
pfSense designations:				
Internal (set by pfSense)	igb0	igb1	igb2	igb3
Functional (set by us)	OPT1	WAN	OPT2	OPT3

You may notice that there's no functional LAN port in the table above. This is because we assigned the LAN port function to a **bridge** unifying OPT1, OPT2, OPT3, and the wireless network (WLAN, aka OPT4, aka ath0). So the port labeled **LAN** actually works as a LAN port, and so do two other ports and the wireless subsystem.

We have configured the **WAN** port to act as DHCP client (i.e., to ask the upstream device for an IP address).

The management interface is accessible **on any LAN port**, including wireless, at <https://192.168.1.1>; the login name is **admin**, the password is **password** (we changed the default pfSense password to get rid of the nagging reminders in the management interface). Take a moment to change the password to something more secure (navigate to **System** >> **User Manager** in the Web-based interface and change the password there).

We have set the SSID (wireless network name) to **Sophos** and the key (wireless password) to **Sophos-Key**. They can be changed at **Interfaces** >> **WLAN**.

Happy networking!

The **ncbase** team