

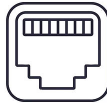

Configuration Notes (Sophos SG 115 Rev 1 and 2)

Thank you for purchasing the Sophos SG 115 network appliance! To make this appliance useful to people who do not have a Sophos license and don't want to get one, we have installed the pfSense operating system and tested this appliance to ensure its working condition.

If you intend to reset pfSense to its initial settings, we still recommend that you read the remainder of this note to familiarize yourself with how pfSense interacts with this device's components.

This model has on-device labeling of physical ports. When configuring pfSense, we made interface designations consistent with this labeling to reduce confusion:

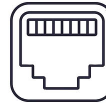
	eth0	eth1	eth2	eth3
On-device markings				
	LAN	WAN	DMZ	HA
pfSense designations:				
Functional (set by us)	LAN	WAN	OPT1	OPT2
Internal (set by pfSense)	igb0	igb1	igb2	igb3

In short, the port labeled **LAN** is now officially a **LAN** port, and same goes for **WAN**.

We have configured the **WAN** port to act as DHCP client (i.e., to ask the upstream device for an IP address). The **LAN** port has been configured to provide DHCP service; its IP address is **192.168.1.1**. The remaining ports have been designated **OPT1** and **OPT2** and left unconfigured.

The management interface is accessible **on the LAN port only** at <https://192.168.1.1>; the login name is **admin**, the password is **password** (we changed the default pfSense password to get rid of the nagging reminders in the management interface). Take a moment to change the password to something more secure (navigate to **System** >> **User Manager** in the Web-based interface and change the password there).

Happy networking!

The **ncbase** team